

UPSTAGING INC.

AUTOMATED HUD TRUSS

24"X14" SPIGOTED

8' & 10'

10' SECTION

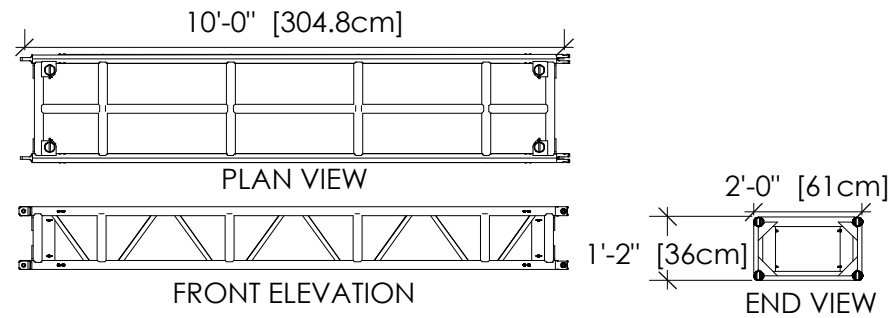

10' SECTION EMPTY

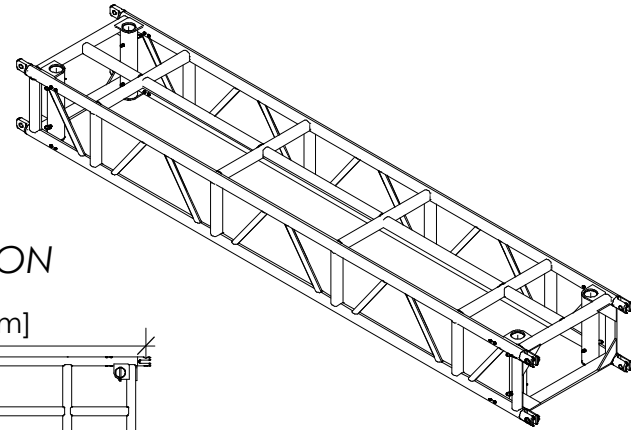

8' SECTION

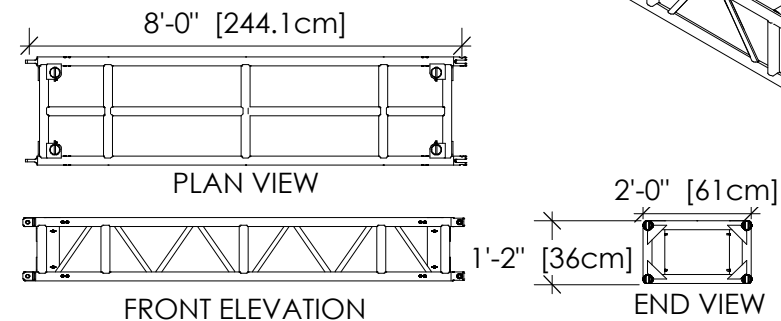

8' SECTION EMPTY

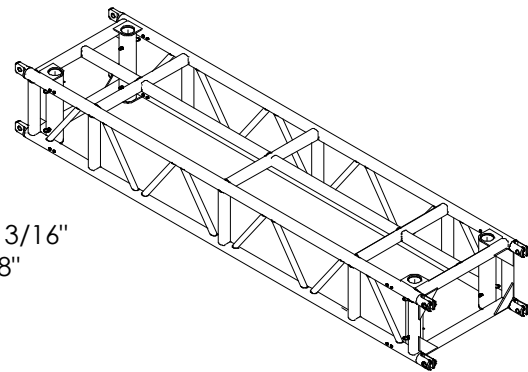

-MAIN CHORDS ARE 2" OD X 3/16"
-DIAGONALS ARE 1" OD X 1/8"

FEATURES

- EQUIPPED WITH ROLLING LEGS FOR QUICK SETUP
- CASTER PLATES ALLOW FOR EASY STACKING
- 24" WIDTH ALLOWS FOUR ROWS TO FIT IN A STANDARD SEMI TRAILER
- PRE-RIG CONFIGURATION CUTS DOWN ON LOAD-IN TIME AND TRUCK SPACE
- LIGHTEST WEIGHT OF ANY AUTOMATED TRUSS
- FIXTURES RIDE IN PLACE, CUTS DOWN ON DAMAGE DURING TRANSPORT
- ADDITIONAL PIECES & ACCESSORIES AVAILABLE, INCLUDING HINGE PLATES & CORNERBLOCKS
- ALLOWS FIXTURES TO ARRIVE ON SITE WITH MANY OF THE ELECTRICAL CONNECTIONS ALREADY MADE, DRASTICALLY CUTTING DOWN MOST ON SITE TROUBLESHOOTING

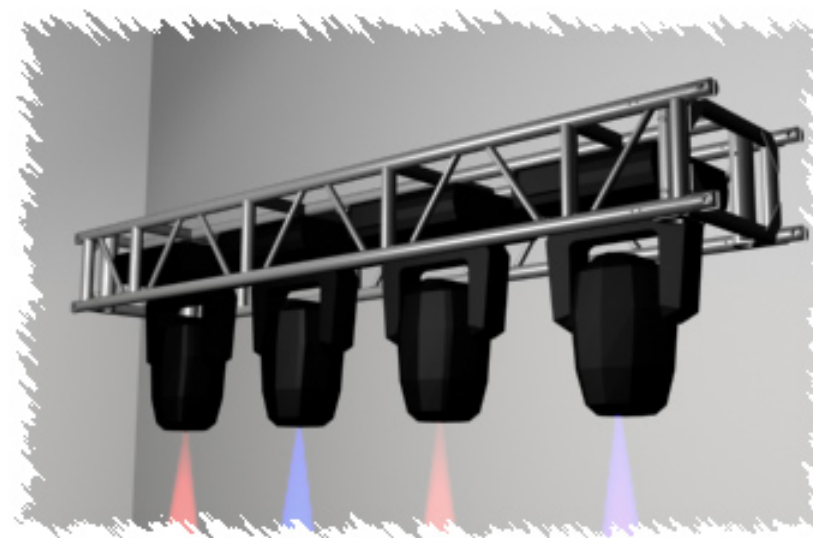

10' SECTION FULL

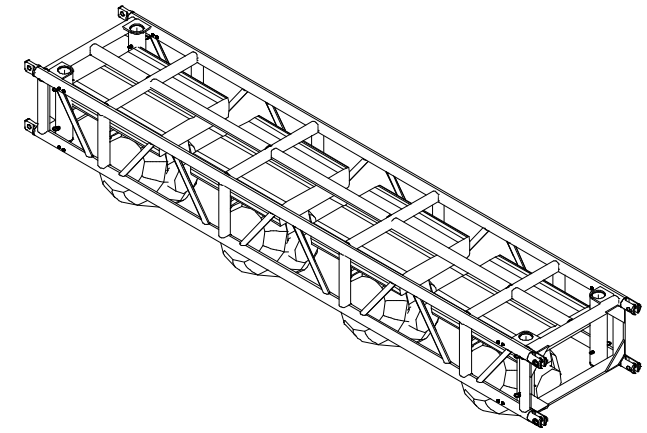

8' SECTION FULL

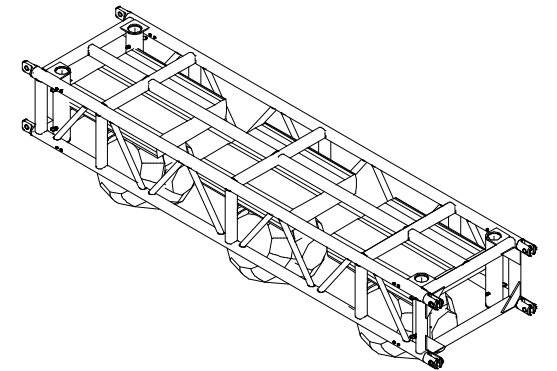

ALLOWABLE LOAD DATA

Span (ft.)	Uniform Load				Point Load at Center		Point Loads at 1/3 Points		Point Loads at 1/4 Points		Selfweight	
	Load (lbs./ft.)	Load (lbs.)	Maximum Deflection (in.)	Load (lbs.)	Maximum Deflection (in.)	Load (lbs.)	Maximum Deflection (in.)	Load (lbs.)	Maximum Deflection (in.)	Load (lbs.)	Maximum Deflection (in.)	
10	690	6,900	0.297	1,630	0.122	2,125	0.263	1,745	0.286	-	0.003	
20	400	8,000	1.176	3,740	0.971	2,235	0.902	1,455	0.844	-	0.026	
30	150	4,500	1.991	1,445	1.120	1,665	2.000	1,175	1.995	-	0.111	
40	62.5	2,500	2.679	1,520	2.669	920	2.678	650	2.665	-	0.335	
50	28	1,400	3.291	880	3.337	520	3.321	375	3.337	-	0.796	
60	13	780	3.998	485	4.009	285	3.987	205	4.000	-	1.629	

Notes:

- 1) The load shown is the allowable load that the truss can support at the given span based on either truss strength or truss deflection limited to span/180.
- 2) The trusses indicated are standalone only. They have not been analysed in a stage configuration.
- 3) The truss capacities are meant for lighting and equipment loads only. Occupancy loads have not been considered and the trusses are not modeled as a work platform or a catwalk.

Span (ft.)	Uniform Load			Point Load at Center		Point Loads at 1/3 Points		Point Loads at 1/4 Points		Selfweight	
	Load (lbs./ft.)	Load (lbs.)	Maximum Deflection (in.)	Load (lbs.)	Maximum Deflection (in.)	Load (lbs.)	Maximum Deflection (in.)	Load (lbs.)	Maximum Deflection (in.)	Load (lbs.)	Maximum Deflection (in.)
8	665	5,320	0.187	2,065	0.142	1,690	0.166	1,335	0.180	-	0.001
16	555	8,880	0.677	4,345	0.602	1,490	0.328	2,070	0.627	-	0.011
24	295	7,080	1.584	2,085	0.865	2,550	1.545	1,440	1.240	-	0.048
32	125	4,000	2.083	2,490	2.131	1,335	1.948	1,070	2.132	-	0.144
40	63	2,520	2.665	1,520	2.661	935	2.659	635	2.662	-	0.342
48	33	1,584	3.186	980	3.189	580	3.179	425	3.242	-	0.699

Notes:

- 1) The load shown is the allowable load that the truss can support at the given span based on either truss strength or truss deflection limited to span/180.
- 2) The trusses indicated are standalone only. They have not been analysed in a stage configuration.
- 3) The truss capacities are meant for lighting and equipment loads only. Occupancy loads have not been considered and the trusses are not modeled as a work platform or a catwalk.

Calculations provided by the THE STRUCTURAL SHOP LTD CONSULTING ENGINEERS Feb 21, 2008

OPERATION

8' SECTION FULL IN TRAVELING CONFIGURATION

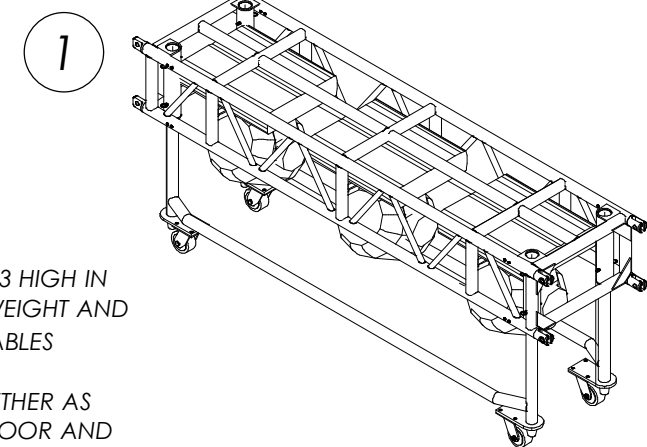

FITS 4 ACROSS BY 2 OR 3 HIGH IN TRUCK DEPENDING ON WEIGHT AND ADDITIONAL VARIABLES

CAN BE PINNED TOGETHER AS COMPLETE TRUSS ON FLOOR AND ROLLED INTO PLACE

8' SECTION FULL IN FLOWN CONFIGURATION

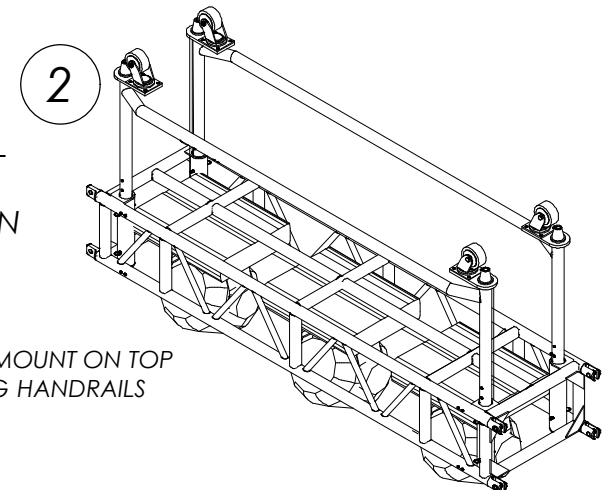

LEGS REMOVE AND MOUNT ON TOP OF TRUSS FORMING HANDRAILS